

S5-50/90, S6-65/66/70/75/80/90, 6S-800/1000/1200 TD/TO  
(Volvo ZTO 1006), 6AS 800/1000TO

## Posterior Neumático Rear Pneumatic



## Descripción Description

Toma de fuerza con 5º tornillo adicional para mejor sujeción de bombas pesadas (ZF Ecosplit, Astronic y TraXon) con nuestras bridas integradas. Accionamiento neumático, salida girada para bombas ISO 4 taladros. Indicador de funcionamiento opcional de bayoneta o presostato.

Rear PTO with a 5th additional bolt for a better support with heavy pumps (ZF Ecosplit, Astronic and TraXon) through our integrated flanges. Pneumatic shifting, ISO 4 bolts pump rotated output.

### Datos Principales Main Data

Datos Principales		Main Data		
Relación Interna Internal Ratio		1: 1.8	1: 1.5	1: 1.3
Par nominal Torque (Nm)	Continuo Continuous	350	400	450
	Intermitente Intermittent	490	560	630
Potencia (1000 r.p.m.) Power (HP) 1000 r.p.m		75 C.V. // 56 Kw	87 C.V. // 65 Kw	97 C.V. // 72 Kw
Lado de montaje Mounting position		Posterior Rear		
Sentido de giro de la bomba Pump rotation		Derecho ClockWise		
Peso Weight (Kg)		11,45		
Relación motor - Toma de Fuerza Engine to PTO ratio		ANEXO I ATTACHMENT I	ANEXO II ATTACHMENT II	ANEXO III ATTACHMENT III

### Códigos y Combinaciones Part Numbers and Combinations

Códigos y Combinaciones		Part Numbers and Combinations	
Tipos de salida Output types		Plato Flange	Bomba Pump (DIN 5462)
Relación Interna Internal Ratio	1: 1.8	1029002	1029003
	1: 1.5	1029102	1029103
	1: 1.3	1029202	1029203

S5-50/90, S6-65/66/70/75/80/90, 6S-800/1000/1200 TD/TO  
(Volvo ZTO 1006), 6AS 800/1000TO

## Posterior Neumático Rear Pneumatic

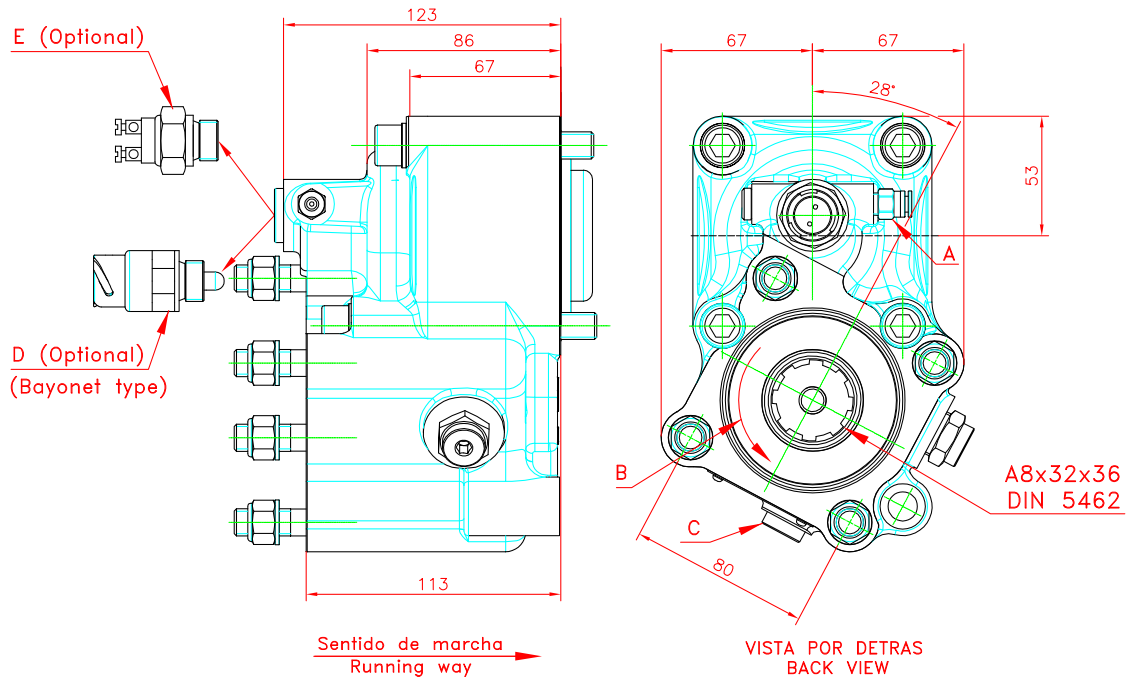

Notas		Notes	
A	Toma de aire, rosca 1/8" GAS.	A	Air connection, thread BSP 1/8"
B	Sentido de giro.	B	Rotation.
C	Tapón de drenaje.	C	Oil drain plug.
D	Interruptor de contacto opcional (9024999)	D	Passing contact switch (Optional) P/N 9024999
E	Interruptor neumático opcional (100070018)	E	Pressure switch (Optional) P/N 100070018

## Tipos de Salida Output Types

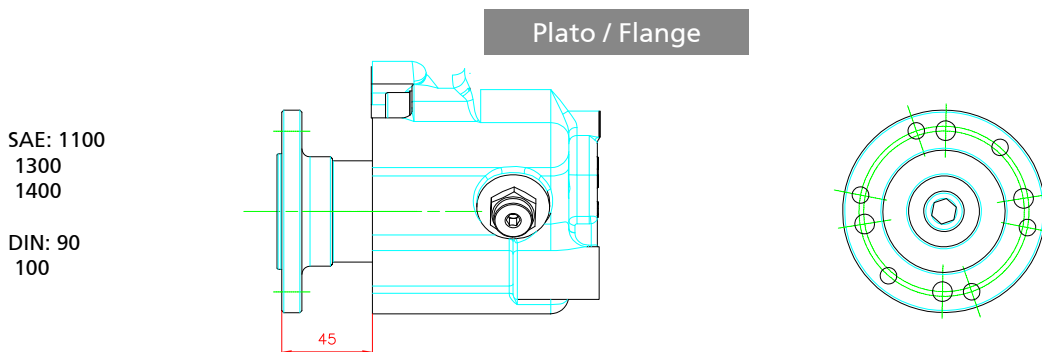

S5-50/90, S6-65/66/70/75/80/90, 6S-800/1000/1200 TD/  
TO (Volvo ZTO 1006), 6AS 800/1000TO

Posterior Neumático (Altas Prestaciones)  
Rear Pneumatic (High Performance)

Anexo I Attachment I

	CAJA GEARBOX	RELACIÓN RATIO	
	/ 5.30	1,175	
	/ 5.50	1,107	
	/ 6.20	0,981	
	/ 6.61	0,918	
S5-50	/ 6.61+GV80	Larga High 1,147	
	/ 5.30	Normal 0,918	
	/ 8.02	0,76	
	/ 8.02+GV80/6.20	Larga High 0,981 Normal 0,758	
S5-90GP	/ GPA	1,602	
	/ 6.37	1,17	
	/ 6.70	1,116	
	/ 7.0+GV70/7.67	Larga High 0,821 Normal 0,657	
S6-65	/ 7.40	1,012	
	/ 7.52	0,999	
	/ 9.00	0,832	
	/ 7.97+GV80/6.70	Larga High 1,116 Normal 0,945	
	/ 9.00+GV80/6.70	Larga High 1,116 Normal 0,832	
	/ 9.00+GV80/7.52	Larga High 0,997 Normal 0,832	
	S6-66	/ 7.36-1.0	0,94
		/ 9.06-1.0	0,749
/ 6.8		0,925	
/ 6.8+GV70/5.71		Larga High 1,102 Normal 0,925	
S6-70	/ 7.36	0,86	
	/ 7.92	0,794	
	/ 9.03	0,697	
	/ 9.59	0,657	
S6-75	/ 6.70+GV80/7.52	Normal 1,116 Corta Low 0,997	
	/ 5.03	1,404	
S6-80	/ 5.66	1,332	

	CAJA GEARBOX	RELACIÓN RATIO
	/ 5.66+GV80/7.52	Larga High 1,328 Normal 1,001
	/ 6.10	1,238
	/ 6.7	1,116
	/ 6.7+GV80/5.30	Larga High 1,417 Normal 1,116
	/ 6.90	0,927
	/ 7.35	0,994
	/ 7.41	1,013
	/ 7.53	0,999
S6-80	/ 7.67	0,972
	/ 7.67+GV80/6.7	Larga High 1,12 Normal 0,977
	/ 7.90	0,945
	/ 9.00	0,828
	/ 9.00+GV80/5.30	Larga High 1,417 Normal 0,832
	/ 9.00+GV80/7.48	Larga High 1,012 Normal 0,832
	/ 9.00+GV80/7.52	Larga High 0,997 Normal 0,832
	/ 5.67	1,35
	/ 5.74	1,332
	/ 6.37	1,332
	/ 6.98	1,102
	/ 7.03	1,085
S6-90	/ 7.03+GV90/5.67	Larga High 1,35 Normal 1,085
	/ 7.03+GV90/5.74	Larga High 1,323 Normal 1,08
	/ 7.40	1,035
	/ 9.01	0,846
	/ 9.01+GV90/7.40	Larga High 1,031 Normal 0,848
	6S800TO/6.58-0.78 (Volvo ZTO 1006)	0,954
	6AS 800 TO/6.58-0.78	0,954
	6AS1000TO/6.75-0.78	0,954
	6S1000TO/6.75 - 0.78	0,954
	6S1200TD/7.72 - 1.00	0,972
	6S1200TO/6.75 - 0.83	1,116

S5-50/90, S6-65/66/70/75/80/90, 6S-800/1000/1200 TD/TO  
(Volvo ZTO 1006), 6AS 800/1000TO

Posterior Neumático (Altas Prestaciones)  
Rear Pneumatic (High Performance)

Anexo II Attachment II

	CAJA GEARBOX	RELACIÓN RATIO		CAJA GEARBOX	RELACIÓN RATIO
	/ 5.30	1: 0,979			
	/ 5.50	1: 0,923		/ 5.66+GV80/7.52	Larga High 1: 1,107 Normal 1: 0,834
	/ 6.20	1: 0,818		/ 6.10	1: 1,032
	/ 6.61	1: 0,765		/ 6.7	1: 0,93
S5-50	/ 6.61+GV80	Larga High 1: 0,956		/ 6.7+GV80/5.30	Larga High 1: 1,181 Normal 1: 0,93
	/ 5.30	Normal 1: 0,765		/ 6.90	1: 0,773
	/ 8.02	1: 0,633		/ 7.35	1: 0,828
	/ 8.02+GV80/6.20	Larga High 1: 0,818 Normal 1: 0,632		/ 7.41	1: 0,844
S5-90GP	/ GPA	1: 1,335		/ 7.53	1: 0,833
	/ 6.37	1: 0,975	S6-80	/ 7.67	1: 0,81
	/ 6.70	1: 0,93		/ 7.67+GV80/6.7	Larga High 1: 0,933 Normal 1: 0,814
	/ 7.0+GV70/7.67	Larga High 1: 0,684 Normal 1: 0,548		/ 7.90	1: 0,788
	/ 7.40	1: 0,843		/ 9.00	1: 0,69
	/ 7.52	1: 0,833		/ 9.00+GV80/5.30	Larga High 1: 1,181 Normal 1: 0,693
S6-65	/ 9.00	1: 0,693		/ 9.00+GV80/7.48	Larga High 1: 0,843 Normal 1: 0,693
	/ 7.97+GV80/6.70	Larga High 1: 0,93 Normal 1: 0,788		/ 9.00+GV80/7.52	Larga High 1: 0,831 Normal 1: 0,693
	/ 9.00+GV80/6.70	Larga High 1: 0,93 Normal 1: 0,693		/ 5.67	1: 1,125
	/ 9.00+GV80/7.52	Larga High 1: 0,831 Normal 1: 0,693		/ 5.74	1: 1,11
S6-66	/ 7.36-1.0	1: 0,783		/ 6.37	1: 1,11
	/ 9.06-1.0	1: 0,624		/ 6.98	1: 0,918
	/ 6.8	1: 0,771		/ 7.03	1: 0,904
	/ 6.8+GV70/5.71	Larga High 1: 0,918 Normal 1: 0,771	S6-90	/ 7.03+GV90/5.67	Larga High 1: 1,125 Normal 1: 0,904
S6-70	/ 7.36	1: 0,717		/ 7.03+GV90/5.74	Larga High 1: 1,103 Normal 1: 0,9
	/ 7.92	1: 0,662		/ 7.40	1: 0,863
	/ 9.03	1: 0,581		/ 9.01	1: 0,705
	/ 9.59	1: 0,548		/ 9.01+GV90/7.40	Larga High 1: 0,859 Normal 1: 0,707
S6-75	/ 6.70+GV80/7.52	Normal 1: 0,93 Corta Low 1: 0,831		6S800TO/6.58-0.78	1: 0,795
	/ 5.03	1: 1,17		(Volvo ZTO 1006)	1: 0,795
S6-80	/ 5.66	1: 1,11		6S1000TO/6.75-0.78	1: 0,795
				6S1200TD/7.72 - 1.00	1: 0,81
				6S1200TO/6.75 - 0.83	1: 0,93
				6AS1000TO/6.75 - 0.78	1: 0,795
				6AS800TO/6.58 - 0.78	1: 0,795

S5-50/90, S6-65/66/70/75/80/90, 6S-800/1000/1200 TD/TO  
(Volvo ZTO 1006), 6AS 800/1000TO

Posterior Neumático (Altas Prestaciones)  
Rear Pneumatic (High Performance)

Anexo III Attachment III

	CAJA GEARBOX	RELACIÓN RATIO
	/ 5.30	1: 0,849
	/ 5.50	1: 0,8
	/ 6.20	1: 0,709
	/ 6.61	1: 0,663
S5-50	/ 6.61+GV80	Larga High 1: 0,828
	/ 5.30	Normal 1: 0,663
	/ 8.02	1: 0,549
	/ 8.02+GV80/6.20	Larga High 1: 0,709
		Normal 1: 0,547
S5-90GP	/ GPA	1: 1,157
	/ 6.37	1: 0,845
	/ 6.70	1: 0,806
	/ 7.0+GV70/7.67	Larga High 1: 0,593
		Normal 1: 0,475
	/ 7.40	1: 0,731
	/ 7.52	1: 0,722
S6-65	/ 9.00	1: 0,601
	/ 7.97+GV80/6.70	Larga High 1: 0,806
		Normal 1: 0,683
	/ 9.00+GV80/6.70	Larga High 1: 0,806
		Normal 1: 0,601
	/ 9.00+GV80/7.52	Larga High 1: 0,72
		Normal 1: 0,601
S6-66	/ 7.36-1.0	1: 0,679
	/ 9.06-1.0	1: 0,541
	/ 6.8	1: 0,668
	/ 6.8+GV70/5.71	Larga High 1: 0,796
		Normal 1: 0,668
S6-70	/ 7.36	1: 0,621
	/ 7.92	1: 0,573
	/ 9.03	1: 0,503
	/ 9.59	1: 0,475
S6-75	/ 6.70+GV80/7.52	Normal 1: 0,806
		Corta Low 1: 0,72
S6-80	/ 5.03	1: 1,014
	/ 5.66	1: 0,962

	CAJA GEARBOX	RELACIÓN RATIO
	/ 5.66+GV80/7.52	Larga High 1: 0,959
		Normal 1: 0,723
	/ 6.10	1: 0,894
	/ 6.7	1: 0,806
	/ 6.7+GV80/5.30	Larga High 1: 1,023
		Normal 1: 0,806
	/ 6.90	1: 0,67
	/ 7.35	1: 0,718
	/ 7.41	1: 0,732
	/ 7.53	1: 0,722
S6-80	/ 7.67	1: 0,702
	/ 7.67+GV80/6.7	Larga High 1: 0,809
		Normal 1: 0,706
	/ 7.90	1: 0,683
	/ 9.00	1: 0,598
	/ 9.00+GV80/5.30	Larga High 1: 1,023
		Normal 1: 0,601
	/ 9.00+GV80/7.48	Larga High 1: 0,731
		Normal 1: 0,601
	/ 9.00+GV80/7.52	Larga High 1: 0,72
		Normal 1: 0,601
	/ 5.67	1: 0,975
	/ 5.74	1: 0,962
	/ 6.37	1: 0,962
	/ 6.98	1: 0,796
	/ 7.03	1: 0,784
S6-90	/ 7.03+GV90/5.67	Larga High 1: 0,975
		Normal 1: 0,784
	/ 7.03+GV90/5.74	Larga High 1: 0,956
		Normal 1: 0,78
	/ 7.40	1: 0,748
	/ 9.01	1: 0,611
	/ 9.01+GV90/7.40	Larga High 1: 0,745
		Normal 1: 0,612
	6S800TO/6.58-0.78 (Volvo ZTO 1006)	1: 0,689
	6S1000TO/6.75-0.78	1: 0,689
	6S1200TD/7.72 - 1.00	1: 0,702
	6S1200TO/6.75 - 0.83	1: 0,806
	6AS1000TO/6.75 - 0.78	1: 0,689
	6AS800TO/6.58 - 0.78	1: 0,689