

12 AS 1800/ 16 AS 2200/ 12 AS 2301/ 16 AS 2601
2 Salidas Independientes / 2 Independent output

Posterior Neumático Reforzado
Rear Pneumatic Heavy Duty



Descripción Description

Toma de fuerza reforzada de doble salida, con lubricación directa. Relaciones internas iguales en ambas salidas 1:1,60. Montaje en el registro frontal de 5 taladros de la caja de cambios.

Heavy duty Power Take-off, twin output, with straight lubrication, same ratio in both outputs 1:1,60. Mounting on rear 5 bolts-window of the Gearbox.

Datos Principales (Ambas salidas) Main Data (Both Outputs)

Par máximo Max. Torque (Nm)	500
Potencia (1000 r.p.m.) Power (HP) 1000 r.p.m	70 C.V // 53 kW
Sentido de giro Sense of rotation	Bomba Pump Derecho Clockwise Plato Flange Izquierdo Anti Clockwise
Relación motor - Toma de Fuerza Engine to PTO ratio	ANEXO ATTACHMENT

Peso Weight (Kg)	22.4
Lado de montaje Mounting side	Posterior Rear
Par máx. continuo en ambas salidas trabajando conjuntamente Max. Continuous Torque for both outputs working together	600 Nm

Códigos y Combinaciones Part Numbers and Combinations

Tipos de salidas Output types	Salida Superior Upper Output	Plato Flange	Plato Flange	Bomba Pump	Bomba Pump (DIN 5462)
	Salida Inferior Bottom Output	Plato Flange	Bomba Pump	Plato Flange	Bomba Pump
Accionamiento neumático Pneumatic shifting		1026952	1026951	1026950	1026953

12 AS 1800/ 16 AS 2200/ 12 AS 2301/ 16 AS 2601 2 Salidas Independientes / 2 Independent output

Posterior Neumático Reforzado
Rear Pneumatic Heavy Duty

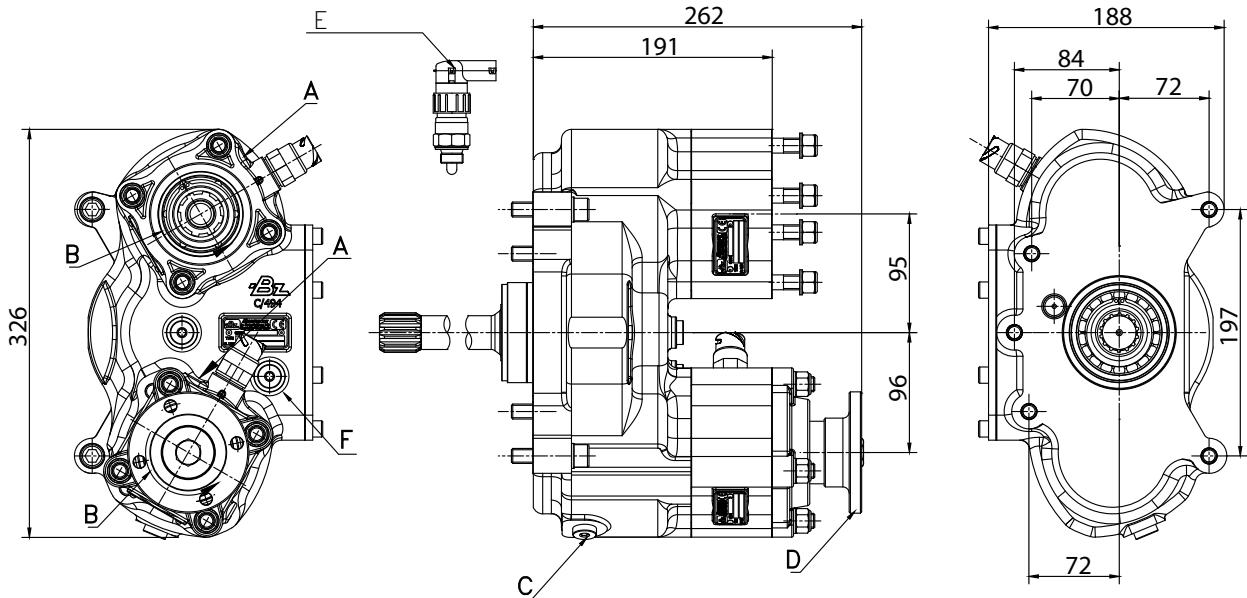

Notas Notes

Trabajo cont.-Alto par: Montar enfriador aceite	On continuous works & high torque: Install an oil cooler
A Toma de aire, rosca 1/8" GAS	A Air connection, thread 1/8" BSP
B Sentido de giro	B Rotation
C Tapón de drenaje del aceite	C Oil drain plug
D Brida de transmisión	D Flange drive
E Interruptores de contacto (9024999)	E Passing contact switches. P/N 9024999
F Conexión del latiguillo de retorno	F Return hose connection

Tipos de Salida Output Types

Plato / Flange

FLANGE TYPE	Part Number	
SAE:	1100	7015504
	1300	
	1400	
DIN:	90	7015804
	100	7015704

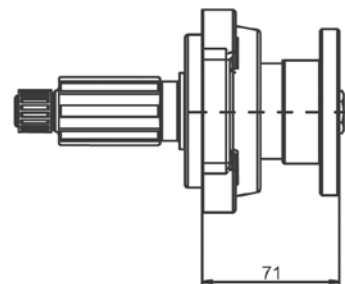
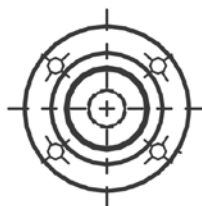

12 AS 1800/ 16 AS 2200/ 12 AS 2301/ 16 AS 2601 2 Salidas
Independientes / 2 Independent output

Posterior Neumático Reforzado
Rear Pneumatic Heavy Duty

CAJA GEARBOX	RELACIÓN RATIO
12AS-2330 TD / 12AS-1630 TD / 1930 TD/ 2130 TD/ 2140 TD / 2340 TD/ 2430 TD/ 2540 TD	/15.86-1.0 1: 1,312
12AS-2331 TD / 12AS-1631 TD/ 1931 TD/ 2131 TD/ 2141 TD / 2301 TD/ 2341 TD/ 2431 TD (+IT)	
12AS-1800	/14.89-1.0 1: 1,216
12AS-1800 (+IT)	
12AS-1930 TO/2130 TO/2330 TO / 2530 TO	/12.33-0.78 1: 2,16
12AS-1931 TO/2131 TO/2301 TO 2331 TO/ 2531 TO (+IT)	
12AS-2540 TO/ 2740 TO/ 2940 TO	/12.29-0.78 1: 2,16
12AS-2541 TO/ 2741 TO/ 2941 TO (+IT)	
16AS-2200	/15.89-1.0 1: 1,136
16AS-2200 (+IT)	
16AS-2230 TD/ 2601 TD	/17.03-1.0 1: 1,216
16AS-2231 TD/ 2601 TD (+IT)	
16AS-2601 TO/ 2630 TO	/14.12-0.83 1: 1,776
16AS-2601 TO/ 2631 TO (+IT)	