

AT-2412C, AT-2412D, AT-2512C, AT-2612D, AT-2612E, AT-2812C, AT-2812D, DT-2412C, R1000, R1400, R1700, SR1400, SR1700, SR1900, SR2000, SRO2400, VVO2512AT, V2812AT, VO3112AT, VT1708, VT2009B, VT2014B, VT2214, VT2412B, VT2514B, VT-2512C, VT-2812C

## Posterior Neumático (1: 1,72) Rear Pneumatic

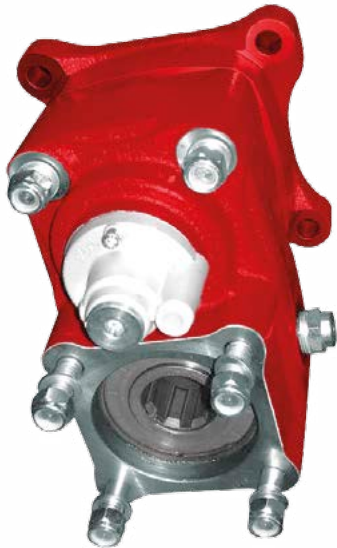

## Descripción Description

Kit de toma de fuerza + brida (sin eje) toma constante 1:1.72 montaje en registro frontal de 4 taladros de la caja de cambios. Accionamiento neumático, salida ISO 4 taladros. Indicador de funcionamiento y eje adaptador opcional.

Base PTO + flange Kit (without shaft) constant mesh 1:1.72 mounting on rear 4 bolts-window of the Gearbox. Pneumatic shifting, output Iso 4 bolts. Optional: Passing contact switch and adapter shaft.

## Datos Principales Main Data

Par nominal Torque (Nm)	Continuo Continuous Intermitente Intermittent		325 450	
Potencia (1000 r.p.m.) Power (1000 r.p.m.)			46 C.V // 34 kW	
Lado de montaje Mounting position			Posterior Rear	
Sentido de giro de la bomba Pump rotation			Derecho Clockwise	
Peso Weight (Kg)			12,5	
Relación motor - Toma de Fuerza Engine to PTO ratio	R1000, R1400, R1700		1: 1,204	
	SR1400, SR1700, SR1900, VT2014B, VT2214B, VT2514B, DT-2412C	Larga High	1: 1,514	
		Normal	1: 1,204	
	SR2000	Larga High	1: 1,410	
		Normal	1: 1,118	
	SRO2400	Larga High	1: 1,775	
		Normal	1: 1,410	
	VT1708, VT2009B AT-2412C, AT-2412D, AT-2512C, AT-2612D, AT-2612E, AT-2812C, AT-2812D, V-2412AT, V-2512AT, V-2812AT, VT-2512C, VT-2812C			1: 1,204
		Larga High		1: 1,552
		Normal		1: 1,204
		Larga High		1: 1,978
	VO2512AT, VO3112AT	Normal		1: 1,548
Larga High			1: 1,880	
VTO2214B, VTO2514B			1: 1,514	
	Normal		1: 1,514	

## Códigos y Combinaciones Part Numbers and Combinations

Kit toma de fuerza base con brida Base PTO Kit with flange		+ Kit de eje adaptador Adapter shaft kit	
		R1000, SR1700, ... (L=267mm)	110104
Salida Plato Flange output	11100K02	R1000, ... Retarder (L=302mm)	110304
Salida Bomba Pump output (DIN 5462)	11100K03	DT-2412C, V2412 (L=229 mm)	116504

AT-2412C, AT-2412D, AT-2512C, AT-2612D, AT-2612E, AT-2812C, AT-2812D, DT-2412C, R1000, R1400, R1700, SR1400, SR1700, SR1900, SR2000, SRO2400, VVO2512AT, V2812AT, VO3112AT, VT1708, VT2009B, VT2014B, VT2214, VT2412B, VT2514B, VT-2512C, VT-2812C

## Posterior Neumático (1: 1,72) Rear Pneumatic

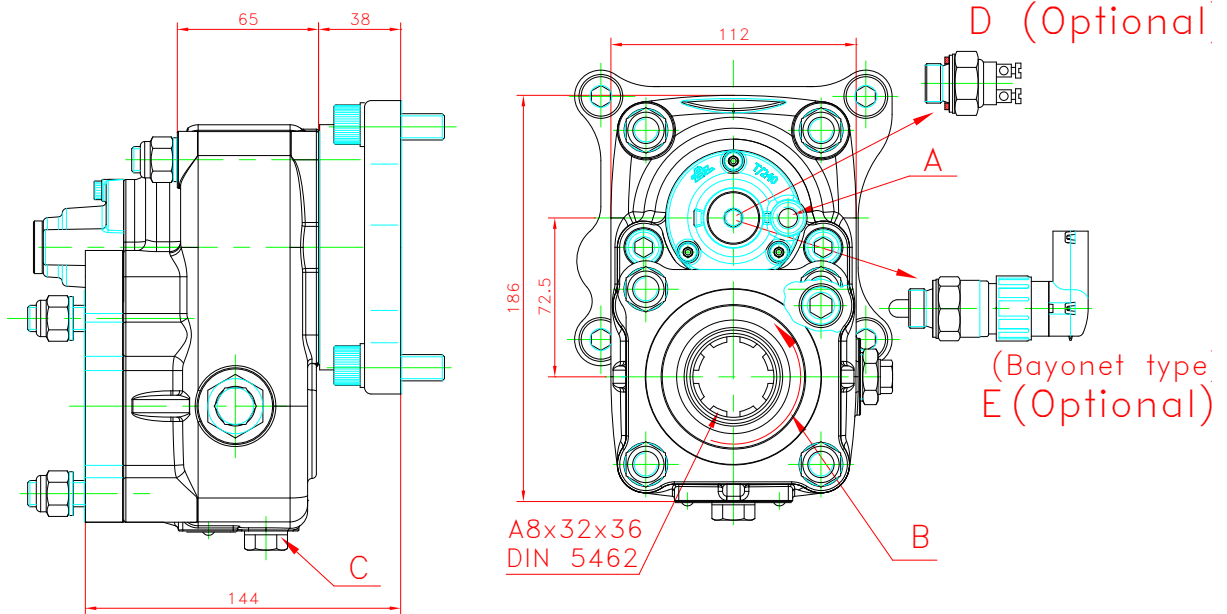

### Notas Notes

A	Toma de aire, rosca 1/8" GAS	A	Air connection, thread 1/8" BSP
B	Sentido de giro	B	Rotation
C	Tapón de drenaje	C	Oil drain plug
D	Interruptor neumático. (100070018)	D	Pressure switch. P/N 100070018
E	Interruptor de contacto. (9024999)	E	Passing contact switch. P/N 9024999

### Tipos de Salida Output Types

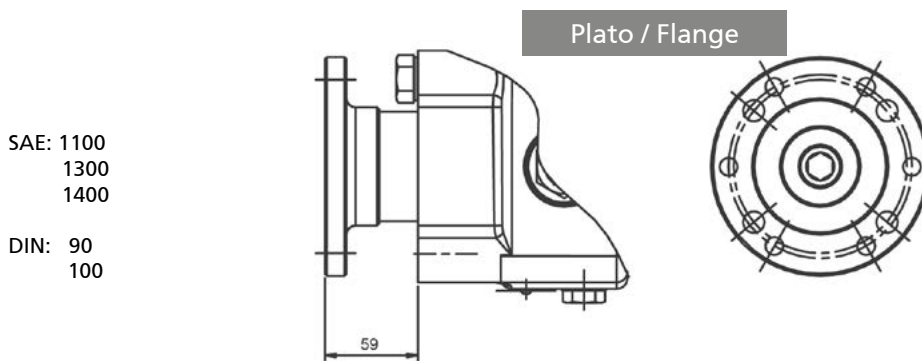

SAE: 1100  
1300  
1400  
DIN: 90  
100