

G4/65, /95, /110

2 Salidas Independientes
2 Independent Outputs

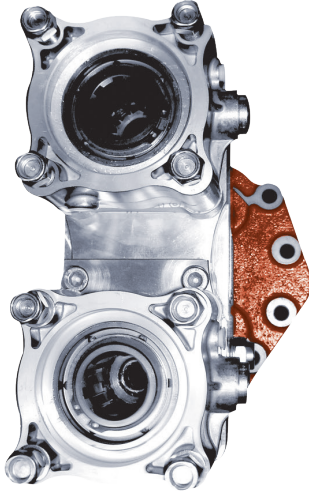

Descripción Description

Toma de fuerza doble salida 3 piñones, relación en salida superior 1:1,30. Relación en salida inferior 1:1,72. Montaje en el registro posterior de 7 taladros de la caja de cambios. Accionamiento neumático. Indicador de funcionamiento opcional.

Power Take-off twin output 3 gears, ratio (upper output) 1:1,30. Ratio (bottom output) 1:1,72. Mounting on rear 7 bolts-window of the Gearbox. Pneumatic shifting. Optional: Passing contact switch.

Datos Generales General Data

Peso Weight (Kg)	12,5
Lado de montaje Mounting side	Posterior Rear
Par máx. continuo en ambas salidas conjuntas Max. Continuous Torque for both outputs	490 Nm. No sobrepasar este par cuando trabajen ambas salidas Don't exceed this torque with both output running.

Datos Principales Main Data

		Salida Superior Upper Output	Salida Inferior Bottom Output
Par nominal Torque (Nm)	Continuo Continuous	350	300
	Intermitente Intermittent	490	420
Potencia (1000 r.p.m.) Power (1000 r.p.m.)		52 C.V // 39 kW	42 C.V // 32 kW
Sentido de giro Sense of rotation	Bomba Pump	Derecho ClockWise	
	Plato Flange	Izquierdo Anti ClockWise	
Relación motor - Toma de Fuerza Engine to PTO ratio		Anexo I Attachment I	Anexo II Attachment II

Códigos y Combinaciones Part Numbers and Combinations

Tipos de salidas Output types	Salida Superior Upper Output	Plato Flange	Plato Flange	Bomba Pump	Bomba Pump
	Salida Inferior Bottom Output	Plato Flange	Bomba Pump	Plato Flange	Bomba Pump (DIN 5462)
Accionamiento neumático Pneumatic shifting		0719552	0719551	0719550	0719553

G4/65, /95, /110

2 Salidas Independientes
2 Independent Outputs

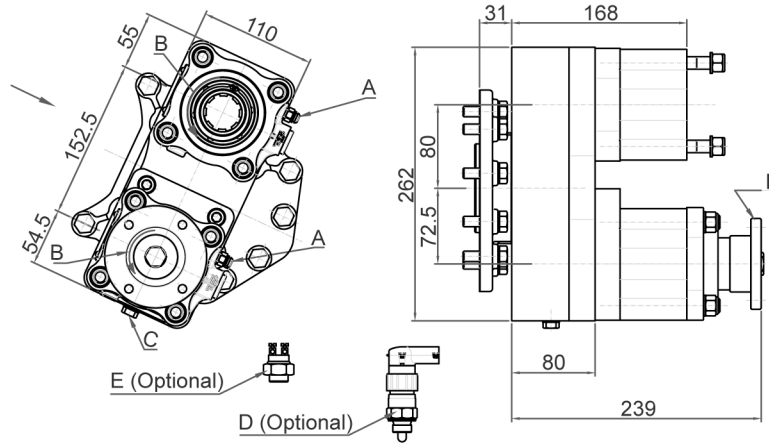

Notas		Notes	
A	Tomas de aire, rosca 1/8" GAS.	A	Air connection, thread BSP 1/8"
B	Sentidos de giro	B	Rotation
C	Tapón de drenaje del aceite	C	Oil drain plug
D	Interruptor de contacto (9024999)	D	Passing contact switch. P/N 9024999
E	Interruptor neumático. (100070018)	E	Pressure switch. P/N 100070018

Anexo I Attachment I		
G4	65-6/9	1: 0,610
	65-7/11	1: 0,532
	95-6/9	1: 0,610
	95-7/11	1: 0,532
GV4 65-6/9	Larga High	1: 0,730
	Normal Normal	1: 0,610
GV4 95- 6/9	Larga High	1: 0,730
	Normal Normal	1: 0,610
GV4 110-6/9	Larga High	1: 0,730
	Normal Normal	1: 0,610

Anexo II Attachment II		
G4	65-6/9	1: 0,807
	65-7/11	1: 0,703
	95-6/9	1: 0,807
	95-7/11	1: 0,703
GV4 65-6/9	Larga High	1: 0,966
	Normal Normal	1: 0,807
GV4 95- 6/9	Larga High	1: 0,966
	Normal Normal	1: 0,807
GV4 110-6/9	Larga High	1: 0,966
	Normal Normal	1: 0,807

Tipos de Salida Output Types

Adaptador Plato / Flange Adapter

SAE:	1100	7015504
	1300	
DIN:	1400	7015604
	90	7015804
	100	7015704

