

07218K03

Mercedes

G131, G210, G211, G141-9, G221, G230, G231, G240, G241, G260,
G280, G281, G330

Posterior Neumático (1: 1,30) Casquillo cierre bomba
Rear Pneumatic (1: 1,30) Closed pump cover

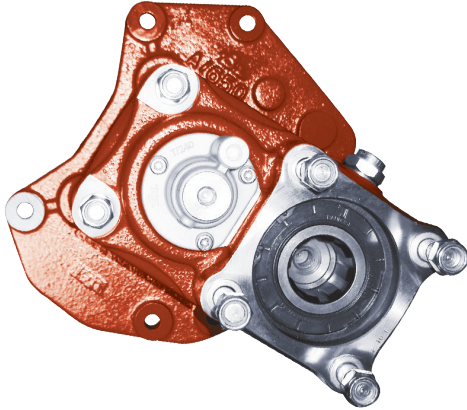

Descripción Description

Kit toma de fuerza reforzada + brida (sin eje), relación 1:1,30 para bombas ISO 4 taladros. Accionamiento neumático. Montaje sobre el registro posterior de 8 taladros de la caja de cambios. Indicador de funcionamiento y/o eje adaptador opcional.

Base PTO + flange kit (without shaft), heavy duty 1:1,30 to connect ISO 4 bolts pumps. Pneumatic shifting. Mounting on rear 8 bolts-window of the Gearbox. Optional: Passing contact switch and adapter shaft.

Datos Principales Main Data

Par máximo Max. Torque (Nm)	Continuo Continuous	400	
	Intermitente Intermittent	570	
Potencia (1000 r.p.m.) Power (1000 r.p.m.)		57 C.V // 43 kW	
Lado de montaje Mounting position		Posterior Rear	
Sentido de giro de la bomba Pump rotation		Derecho ClockWise	
Peso Weight (Kg)		18	
Relación motor - Toma de Fuerza Engine to PTO ratio	G131-9/14.57-1.0		1:0,959
	G210-16/14.2-0.83	Normal Normal	1:1,105
		Larga High	1:1,339
	G141-9/14.57-1.0, G211-16/17.0, G231-16/17.0, G241-16K/17.0-1.0	Normal Normal	1:0,923
		Larga High	1:1,105
	G221-9/16.15-1.0		1:0,962
	G240-16/11.7, G280-16K/11.72-0.69, G280-16/11.72-0.69 NewAMT	Normal Normal	1:1,339
		Larga High	1:1,612
	G260-16/9.75-0.57	Normal Normal	1:1,612
		Larga High	1:1,95
	G211-12K/14.93-1.0, G211-12/14.93-1.0 NewAMT, G281-12K/14.93-1.0, G281-12K/14.93-1.0, G281-12/14.93-1.0 NewAMT	Normal Normal	1:1,053
		Larga High	1:1,339
	G230-12K/11.67-0.78, G230-12/11.67-0.78 NewAMT, G230-16S/14.2-0.83, G330-12K/11.64-0.78, G330-12/11.64-0.78 NewAMT	Normal Normal	1:1,339
		Larga High	1:1,716

Códigos y Combinaciones Part Numbers and Combinations

Kit toma de fuerza Base con brida Base PTO kit with flange + Kit de eje adaptador Adapter shaft kit			
Salida Plato Flange Output	07218K02	G131 ... G330, Z=16. L=252mm	700904
		G131 ... G330, Retarder. Z= 16. L=277mm	703704
Salida bomba Pump Output DIN 5462	07218K03	G281 Powershift 3, Z=16. L=293mm (Aquatarder)	7018104
		G281-12 Powershift 3 Z=16. L=268mm	7018304

G131, G210, G211, G141-9, G221, G230, G231, G240, G241, G260, G280, G281, G330

Posterior Neumático (1: 1,30) Casquillo cierre bomba
Rear Pneumatic (1: 1,30) Closed pump cover

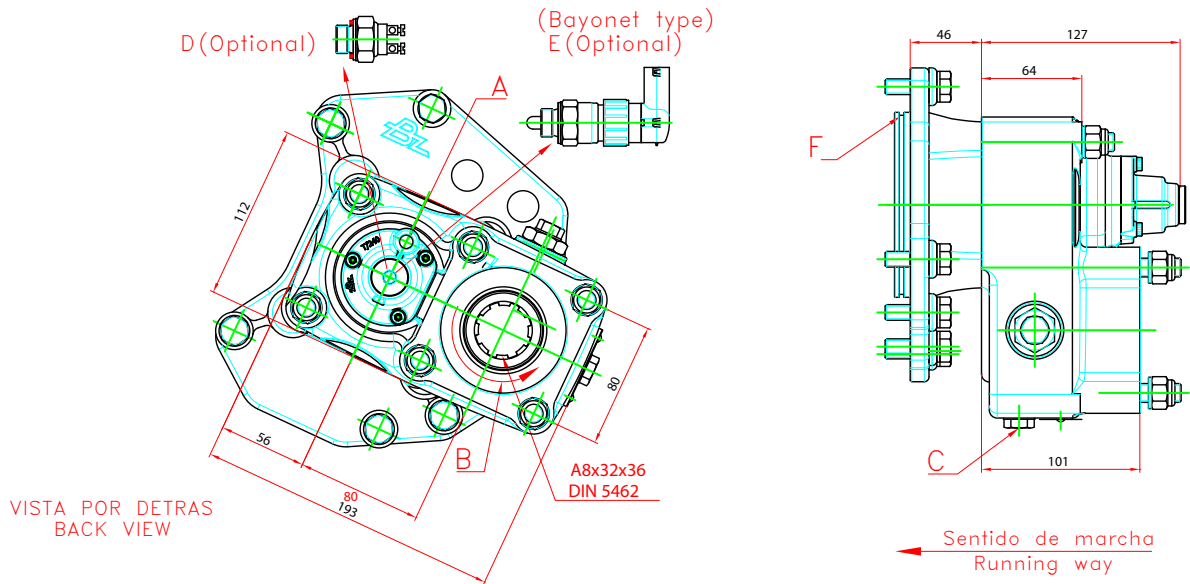

Notas		Notes	
A	Toma de aire, rosca 1/8" GAS	A	Air connection, thread 1/8" BSP
B	Sentido de giro	B	Rotation
C	Tapón de drenaje del aceite	C	Oil drain plug
D	Interruptor neumático (100070018)	D	Pressure switch. P/N 100070018
E	Interruptor de contacto.(9024999)	E	Passing contact switch. P/N 9024999
F	Casquillo cierre bomba de engrase	F	Closed lubrication pump cover

Tipos de Salida Output Types

Adaptador Plato / Flange Adapter

FLANGE TYPE

- 1100
- SAE: 1300
- 1400
- 90
- DIN: 100

