

G-100, G140-8

2 Salidas Independientes
2 Independent Outputs

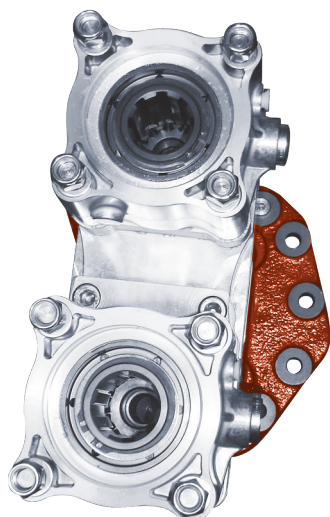

Descripción Description

Toma de fuerza doble salida 3 piñones, relación en salida superior 1:1,30. Relación en salida inferior 1:1,72. Montaje en el registro posterior de 7 taladros de la caja de cambios. Accionamiento neumático. Indicador de funcionamiento opcional.

Power Take-off twin output 3 gears, ratio (top output) 1:1,30. Ratio (bottom output) 1:1,72. Mounting on rear 7 bolts-window of the Gearbox. Pneumatic shifting. Optional: Passing contact switch.

Datos Generales General Data

Peso Weight (Kg)	14
Lado de montaje Mounting side	Posterior Rear
Par máx. continuo en ambas salidas conjuntas Max. Continuous Torque for both outputs	490 Nm. No sobrepasar este par cuando trabajen ambas salidas Don't exceed this torque with both output running.

Datos Principales

Main Data

Salida Superior Upper Output

Salida Inferior Bottom Output

	Continuo Continuous	350	300	
Par nominal Torque (Nm)	Intermitente Intermittent	490	420	
Potencia (1000 r.p.m.) Power (1000 r.p.m.)		52 C.V // 39 kW	42 C.V // 32 kW	
Sentido de giro Sense rotation	Bomba Pump	Derecho ClockWise		
	Plato Flange	Izquierdo Anti ClockWise		
Relación motor - Toma de Fuerza Engine to PTO ratio	G 100	Larga High	1: 0,66	
		Corta Low	1: 0,54	
	G 140-8	Larga High	1: 0,99	1: 1,31
		Corta Low	1: 0,62	1: 0,83

Códigos y Combinaciones

Part Numbers and Combinations

Tipos de salidas Output types	Salida superior Top output	Plato Flange	Plato Flange	Bomba Pump	Bomba Pump
	Salida inferior Bottom output	Plato Flange	Bomba Pump	Plato Flange	Bomba Pump
Accionamiento neumático Pneumatic shifting		0719652	0719651	0719650	0719653

G-100, G140-8

2 Salidas Independientes
2 Independent Outputs

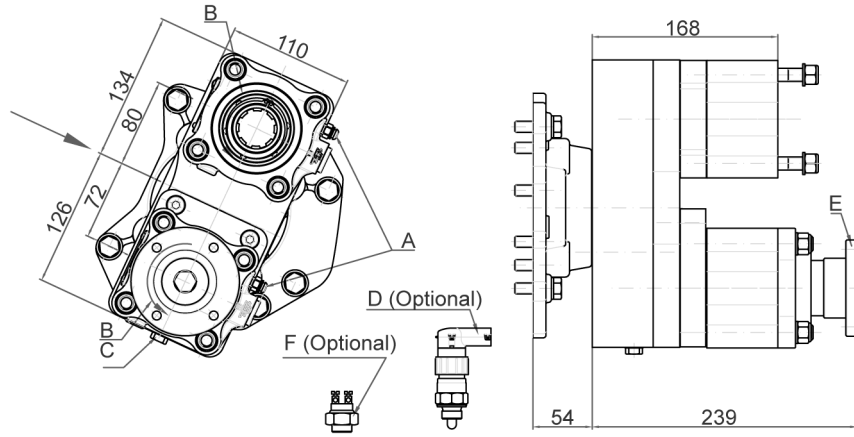

Notas		Notes	
A	Tomas de aire, rosca 1/8" GAS.	A	Air connection, thread BSP 1/8"
B	Sentidos de giro	B	Rotation
C	Tapón de drenaje del aceite	C	Oil drain plug
D	Interruptor de contacto (9024999)	D	Passing contact switch. P/N 9024999
E	Brida de transmisión	E	Flange drive
F	Interruptor neumático (100070018)	F	Pressure switch. P/N100070018

Tipos de Salida Output Types

Adaptador Plato / Flange Adapter

	1100	7015504
SAE:	1300	
	1400	7015604
	90	7015804
DIN:	100	7015704

