

MH4D - ORDERING CODE & OPERATING CHARACTERISTICS

DATA SHEET

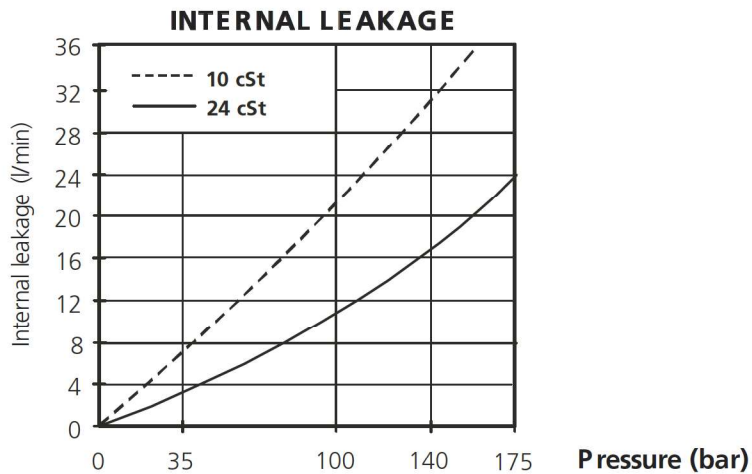
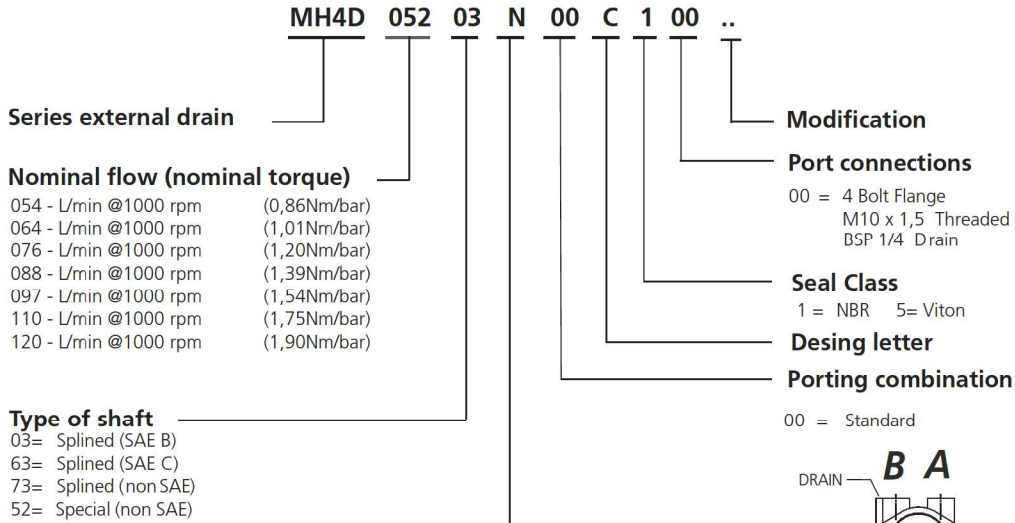

DIMENSIONS, SHAFTS & PORT CONNECTIONS - MH4D

DIMENSIONS IN MILLIMETERS. 1" = 25,4 mm

PORT CONNECTIONS

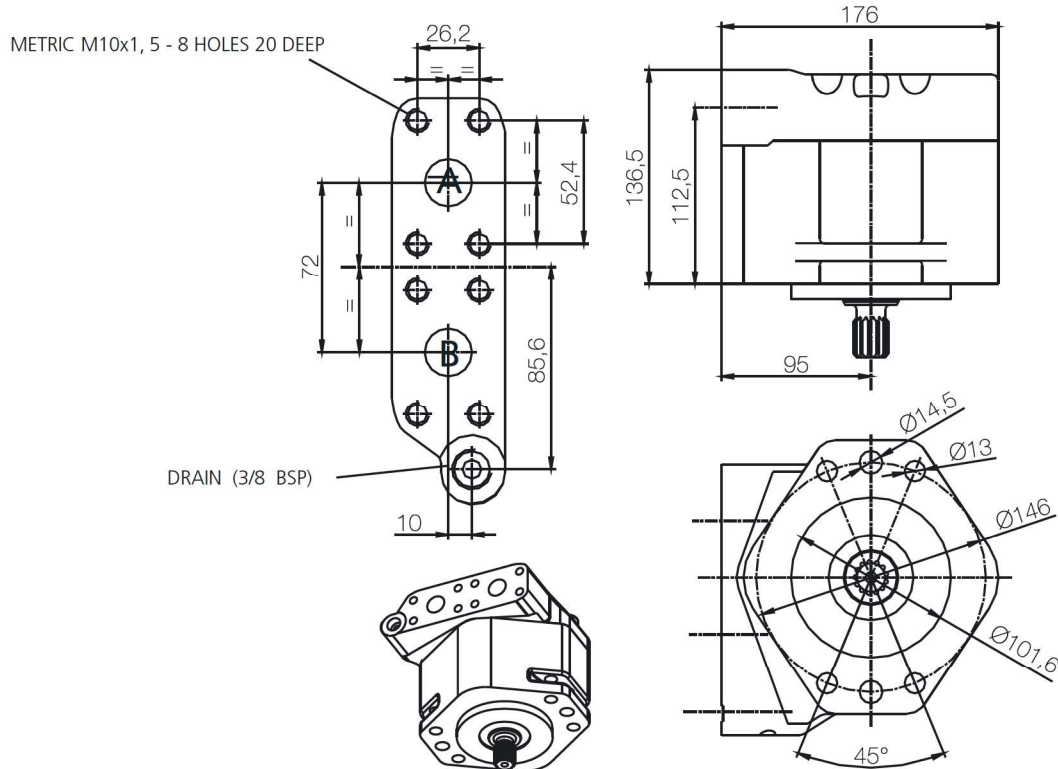

SHAFT TYPE

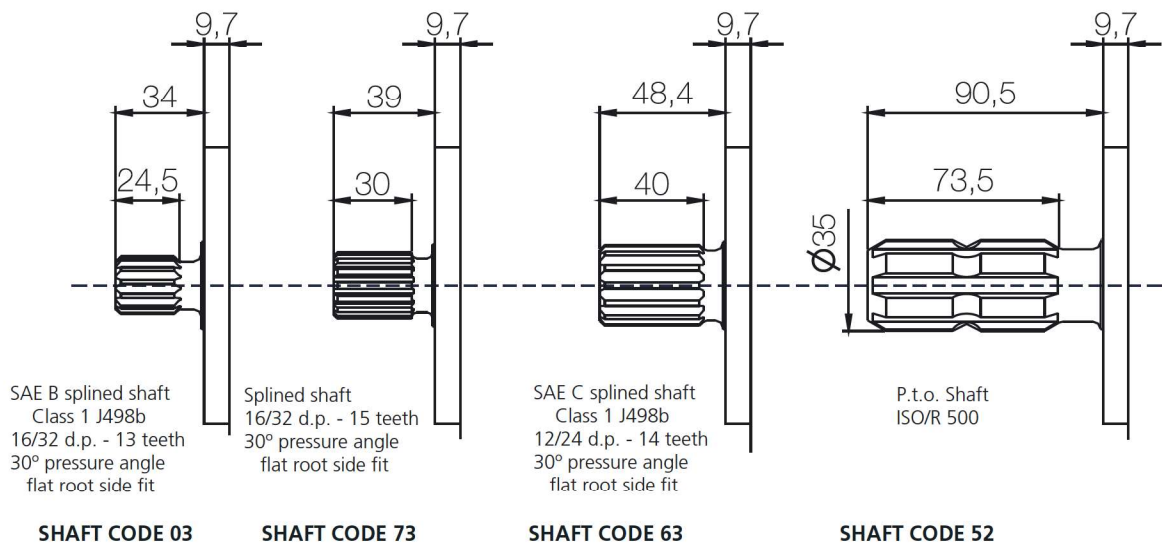

Enquire about other types of shafts

PERFORMANCE CURVES - OIL VISCOSITY : 24 CST (45°) - MH4D

DATA SHEET

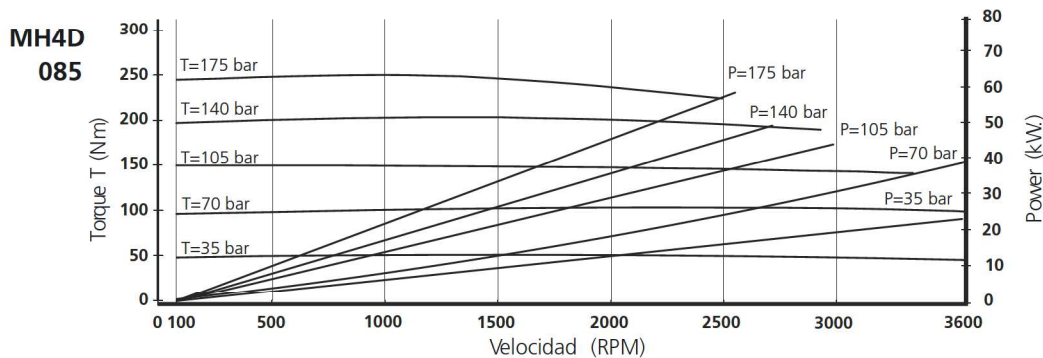
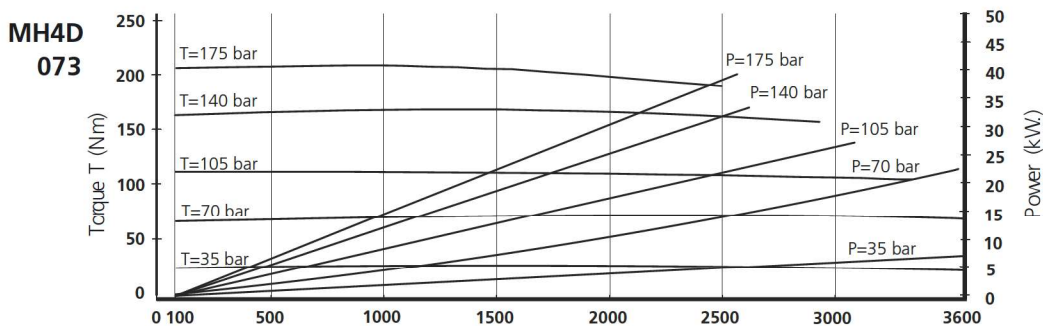
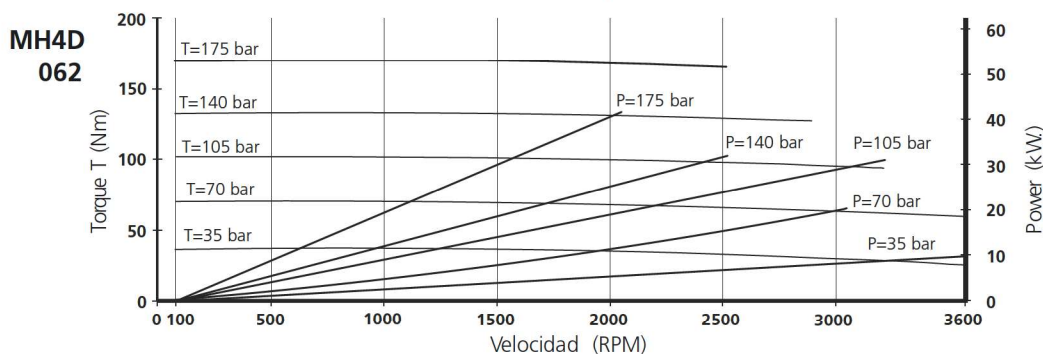
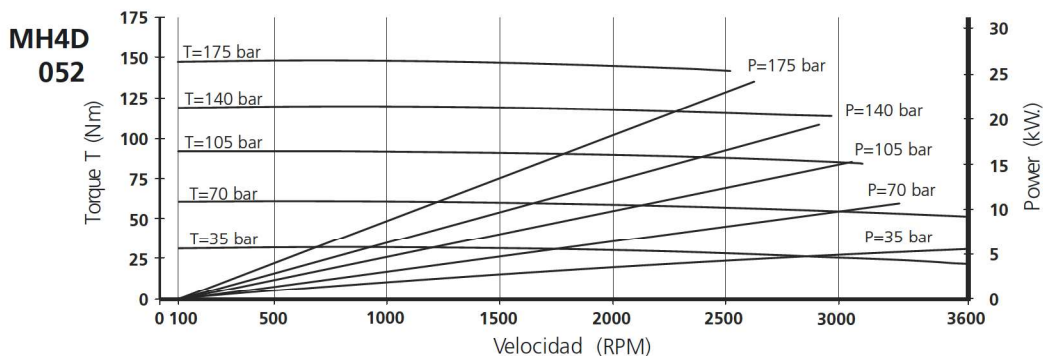

PERFORMANCE CURVES - OIL VISCOSITY : 24 CST (45°) - MH4D

